

# ANTARES 20 / 30



## BESCHREIBUNG | DESCRIPTION

hochwertige Scheibenleuchte im schlanken Design für das Lichtbandsystem  
high quality display luminaire in slimline design for lighting strip system

**Erkennungsweite** 20 m / 30 m  
*viewing distance*

**Schutzart** IP40  
*protection degree*

**Schutzklasse** I  
*protection class*

**Gehäuse** Stahlblech verzinkt, weiß RAL 9016  
*housing* galvanized steel sheet, white RAL 9016

CPS

LPS

SC

## TECHNISCHE DATEN | SPECIFICATIONS

Versorgung <i>supply</i>	Anschlussspannung <i>supply voltage</i> (AC/DC)	Anschlussleistung <i>power rating</i> (AC/DC)	Umgebungstemperatur <i>ambient temperature</i>	LiFePo4-Akku <i>LiFePo4 accu</i>
Zentralbatterie <i>central battery</i> CPS / LPS	230 V / 216 V	8,5 VA / 4,0 W	-10° C <> +40° C	-
Einzelbatterie <i>single battery</i> SC	230 V / -	7,0 VA / -	-5° C <> +35° C	3 h / 8 h

MAßE | DIMENSION (mm)

ZUBEHÖR | ACCESSORIES

ANTARES 20

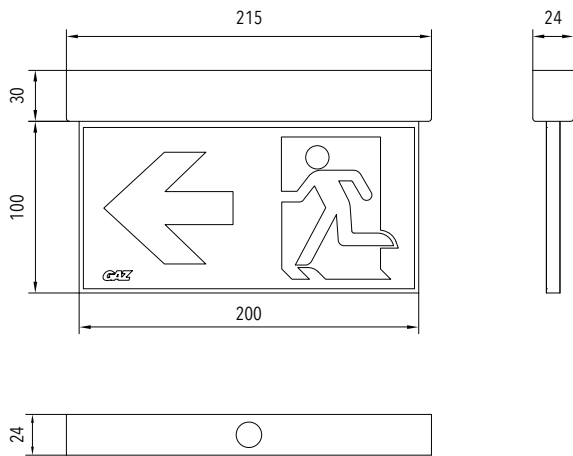

Bezeichnung | designation

Sonderpiktogramme

special pictograms

ANTARES 30

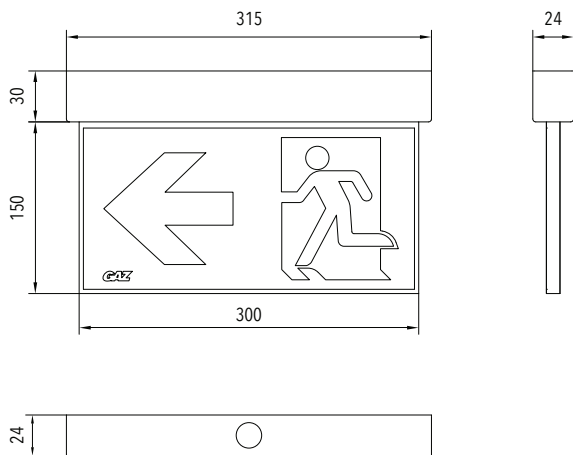

erforderliche Maße des Lichtbandsystems  
required dimensions of lighting strip system

